

SLB Series Subminiature RF Connectors

ONLINE
CATALOG

Slide-on mating
Frequency range DC-4 GHz
Float mount / blind-mate versions



SMB and SMC connectors also shown for comparison



APPLIED ENGINEERING PRODUCTS

104 John W. Murphy Drive • P.O. Box 510 • New Haven, CT 06513

(203) 776-2813 • FAX (203) 776-8294

www.aepconnectors.com • e-mail: aepsales@aepconnectors.com

SLB Subminiature Connectors

Click on any line below to go directly to the appropriate page

Contents

Technical Information

Interfaces and specifications	2
Cable attachment methods	3

Cable Connectors

Straight plugs for flexible and semi-rigid cable	4
Right angle plugs for flexible and semi-rigid cable	4
Bulkhead mounted plugs for flexible and semi-rigid cable	5
Straight jacks for flexible and semi-rigid cable	6
Right angle jacks for flexible and semi-rigid cable	6
Straight bulkhead jacks for flexible and semi-rigid cable	7
Right angle bulkhead jacks for flexible and semi-rigid cable	7

Receptacles

Straight and right angle bulkhead jack receptacles	8
Straight and right angle bulkhead plug receptacles	9
Straight P.C. board jacks	10
Straight bulkhead mounted P.C. board jacks	10
Straight P.C. board plugs	10
Right angle P.C. board jacks	11
Right angle bulkhead mounted P.C. board jacks	11
Right angle P.C. board plugs	11

Float Mount / Blind Mate Connectors

Introduction	12
Bulkhead mounted plugs for flexible and semi-rigid cable	13
Straight bulkhead jacks for flexible and semi-rigid cable	14
Right angle bulkhead jacks for flexible and semi-rigid cable	15
Straight bulkhead jack receptacles	16
Straight bulkhead plug receptacles	17
Straight and right angle bulkhead mounted P.C. board jacks	18
Straight and right angle P.C. board plugs (closed-entry mating end hoods)	19

Vibration-Proof Float Mount Plugs

Introduction	20
Straight plugs for flexible cable	21
Right angle plugs for flexible cable	21

Adapters

Straight adapters within series	22
---	----

Cable Assembly Instructions

Clamp type connectors for flexible cable	23
Crimp type connectors for flexible cable	24
Solder-clamp connectors for semi-rigid cable	25

Assembly Tooling	26
-----------------------------------	-----------

Mounting Dimensions	26
--------------------------------------	-----------

Index by AEP Part Number	27
---	-----------

About AEP	28
----------------------------	-----------

Other AEP Product Lines	29
--	-----------



APPLIED ENGINEERING PRODUCTS

104 John W. Murphy Drive • P.O. Box 510 • New Haven, CT 06513

(203) 776-2813 • FAX (203) 776-8294

www.aepconnectors.com • e-mail: aepsales@aepconnectors.com

SLB Specifications

Specifications (MIL-PRF-39012 as applicable)

Materials:

Body components, male contacts: Brass per ASTM-B-16, alloy 360, 1/2 hard.

Female contacts: Beryllium copper per ASTM-B-196, Condition HT.

Insulators: Teflon TFE per ASTM-D-1710.

Finish:

Center contacts: Gold plated per current revision of MIL-PRF-39012*

Other metal parts: Gold or nickel plated to meet current MIL-PRF-39012 corrosion requirements.*

Electrical:

Impedance: 50Ω. **Frequency range:** DC–4 GHz. **Insulation Resistance:** 1,000 megohms minimum.

Voltage Rating: 250VRMS @ sea level (RG-178 cable); 335VRMS @ sea level (RG-316 cable).

Dielectric Withstanding Voltage: 750VRMS @ sea level (RG-178 cable); 1000VRMS @ sea level (RG-316 cable).

Contact Resistance:

Straight connectors: Initial: 6 milliohms maximum; after environmental test conditions: 8 milliohms maximum.

Right angle connectors: Initial: 12 milliohms maximum; after environmental test conditions: 16 milliohms maximum.

Corona level: 125V @70,000 ft. **RF highpot:** 400 VRMS @ 5 MHz.

RF leakage: -55 dB min @ 2–3 GHz. **Insertion loss:** .30 dB max (straight connectors), .60 dB max (right angle connectors) @ 1.5 GHz.

VSWR:	Cable	Straight connector	Right angle connector
	RG-178	$1.30 + (.04 \times F[\text{GHz}])$	$1.45 + (.06 \times F[\text{GHz}])$
	RG-316	$1.25 + (.04 \times F[\text{GHz}])$	$1.35 + (.04 \times F[\text{GHz}])$

Mechanical:

Force to engage: 6 pounds max.

Contact retention: 2 pounds min axial force. **Durability:** 500 mating cycles.

Environmental (MIL-STD-202):

Temperature range: -65° C to +165° C. **Corrosion:** Method 101, condition B, 5% salt solution.

Vibration (Method 204): N/A.

Mechanical shock (Method 213): N/A. **Thermal shock (Method 107):** Condition B.

*These specifications change periodically with updates to MIL-PRF-39012 requirements. Contact factory for latest specifications.

Interface Dimensions

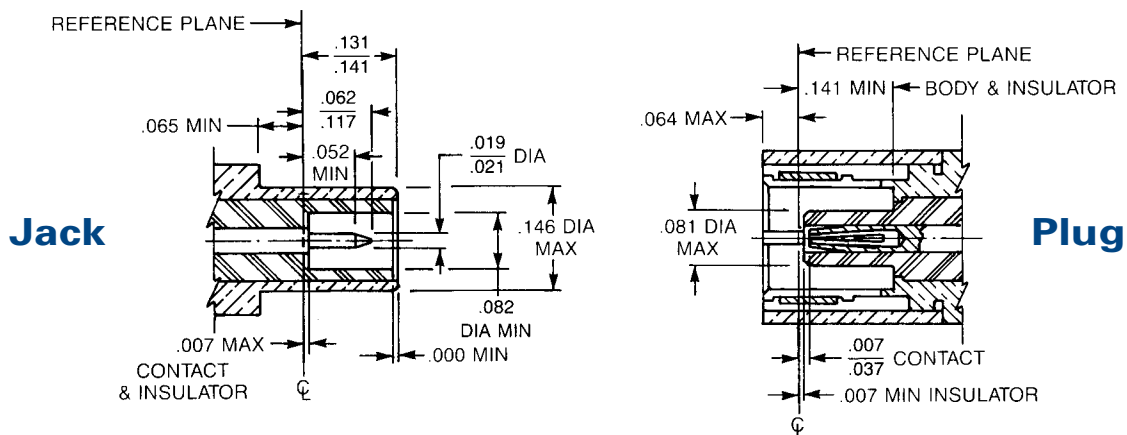

SLB Cable Attachment Methods

All SLB cable connectors in this catalog have captivated contacts which are soldered to the cable center conductor.

Both crimp and clamp types for flexible cable grip the cable braid with a force greater than the breaking strength of the braid.

Clamp Type For Flexible Cable

These connectors can be assembled without special tooling, and are field replaceable. They provide metal-to-metal clamping of the cable braid.

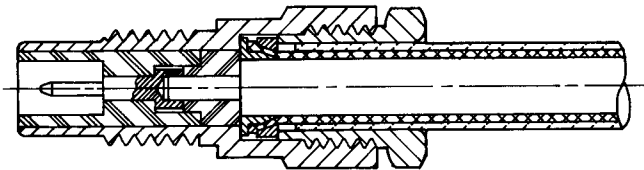

Crimp Type For Flexible Cable

Crimping the cable braid is the most reliable and repeatable method of cable assembly, and provides support for the cable during flexure. AEP crimp type connectors are assembled quickly and easily using readily-available commercial or MIL crimp tools.

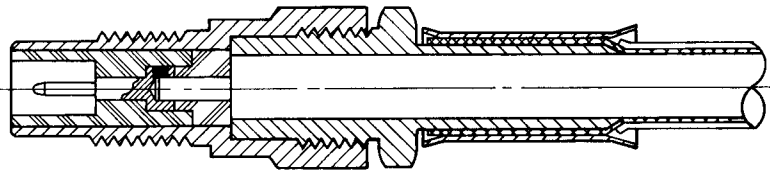

Solder-Clamp For Semi-Rigid Cable

This method allows retrimming of the cable dielectric, if necessary, during assembly. Connectors can be repositioned relative to the cable after assembly by loosening the clamp nut. Solder-clamp connectors are field replaceable without special tools.

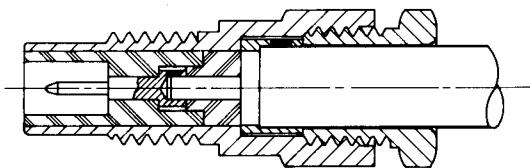

SLB Cable Plugs

Click on part number to go directly to cable assembly instructions

Straight Plugs

Straight Female Cable Plug

Clamp type for flexible cable:

3002-1551-0XX (Gold plated)

3002-7551-0XX (Nickel plated)

Solder-clamp for semi-rigid cable:

3002-1541-0XX (Gold plated)

3002-7541-0XX (Nickel plated)

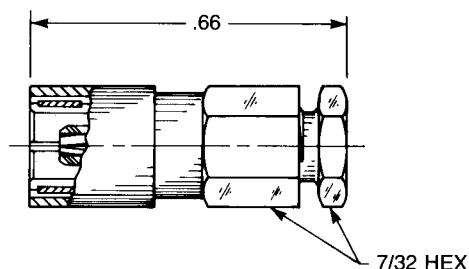

Straight Female Cable Plug

Crimp type for flexible cable:

3002-1571-0XX (Gold plated)

3002-7571-0XX (Nickel plated)

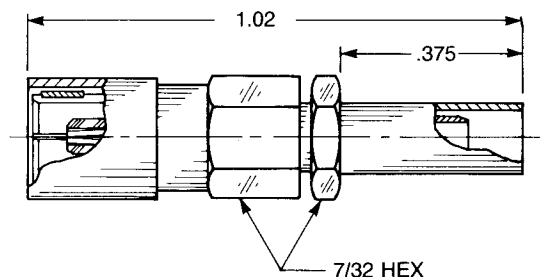

Right Angle Plugs

Right Angle Female Cable Plug

Clamp type for flexible cable:

3005-1551-0XX (Gold plated)

3005-7551-0XX (Nickel plated)

Solder-clamp for semi-rigid cable:

3005-1541-0XX (Gold plated)

3005-7541-0XX (Nickel plated)

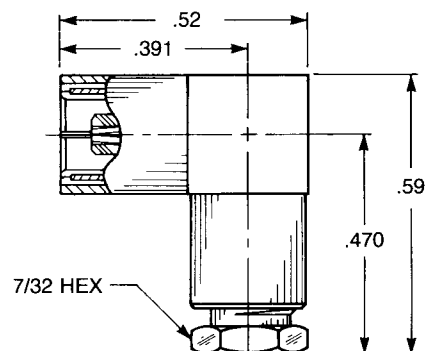

Right Angle Female Cable Plug

Crimp type for flexible cable:

3105-1521-0XX (Gold plated)

3105-7521-0XX (Nickel plated)

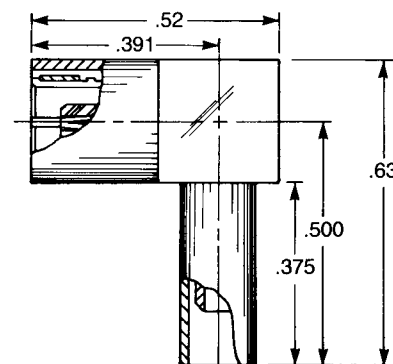

Substitute the appropriate cable group number for "XX" when ordering:

GROUP	CABLE TYPES	GROUP	CABLE TYPES	GROUP	CABLE TYPES
02	RG178, RG196, M17/93, M17/169	05	RG178DS, RG196DS	10	.085" semi-rigid, RG405, M17/133
03	RG174, RG179, RG316, M17/113, M17/119, M17/172, M17/189	09	.141" semi-rigid, RG 402M17/130	19	RG174DS, RG316DS, M17/151, M17/152, Times RD-316



APPLIED ENGINEERING PRODUCTS

(203) 776-2813 • FAX (203) 776-8294

www.aepconnectors.com • aepsales@aepconnectors.com

SLB Cable Plugs

Click on part number to go directly to cable assembly instructions

Straight Bulkhead Mounted Plugs

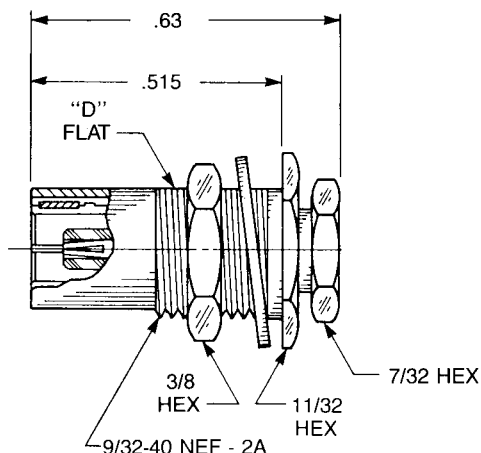

Bulkhead Mounted Straight Female Cable Plug

Clamp type for flexible cable:
3028-1551-0XX (Gold plated)
3028-7551-0XX (Nickel plated)

Solder-clamp for semi-rigid cable:
3028-1541-0XX (Gold plated)
3028-7541-0XX (Nickel plated)

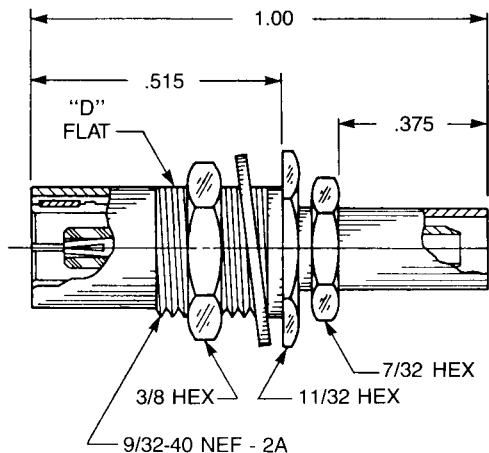

Bulkhead Mounted Straight Female Cable Plug

Crimp type for flexible cable:
3028-1571-0XX (Gold plated)
3028-7571-0XX (Nickel plated)

Substitute the appropriate cable group number for "XX" when ordering:

GROUP	CABLE TYPES	GROUP	CABLE TYPES	GROUP	CABLE TYPES
02	RG178, RG196, M17/93, M17/169	05	RG178DS, RG196DS	10	.085" semi-rigid, RG405, M17/133
03	RG174, RG179, RG316, M17/113, M17/119, M17/172, M17/189	09	.141" semi-rigid, RG 402M17/130	19	RG174DS, RG316DS, M17/151, M17/152, Times RD-316



APPLIED ENGINEERING PRODUCTS

(203) 776-2813 • FAX (203) 776-8294

www.aepconnectors.com • aepsales@aepconnectors.com

SLB Cable Jacks

Click on part number to go directly to cable assembly instructions

Straight Jacks

Straight Male Cable Jack

Clamp type for flexible cable: Solder-clamp for semi-rigid cable:
 3001-1551-0XX (Gold plated) 3001-1541-0XX (Gold Plated)
 3001-7551-0XX (Nickel plated) 3001-7541-0XX (Nickel plated)

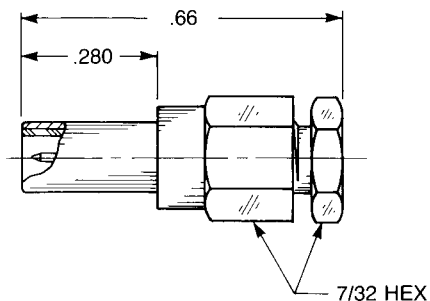

Straight Male Cable Jack

Crimp type for flexible cable:
 3001-1571-0XX (Gold plated)
 3001-7571-0XX (Nickel plated)

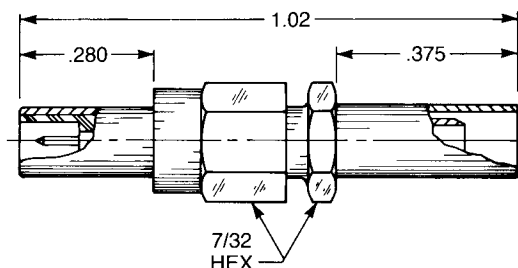

Right Angle Jacks

Right Angle Male Cable Jack

Clamp type for flexible cable:
 3041-1551-0XX (Gold plated)
 3041-7551-0XX (Nickel plated)

Solder-clamp for semi-rigid cable:
 3041-1541-0XX (Gold plated)
 3041-7541-0XX (Nickel plated)

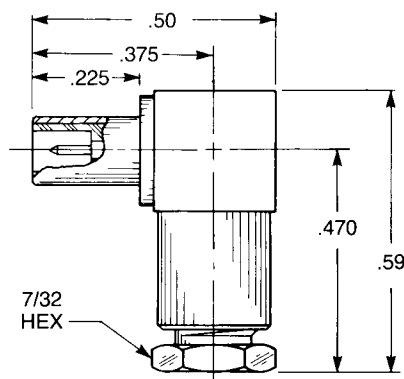

Right Angle Male Cable Jack

Crimp type for flexible cable:
 3141-1521-0XX (Gold plated)
 3141-7521-0XX (Nickel plated)

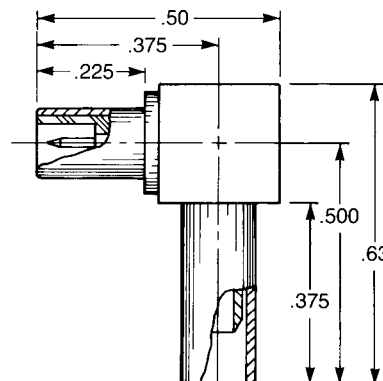

Substitute the appropriate cable group number for "XX" when ordering:

GROUP	CABLE TYPES	GROUP	CABLE TYPES	GROUP	CABLE TYPES
02	RG178, RG196, M17/93, M17/169	05	RG178DS, RG196DS	10	.085" semi-rigid, RG405, M17/133
03	RG174, RG179, RG316, M17/113, M17/119, M17/172, M17/189	09	.141" semi-rigid, RG 402M17/130	19	RG174DS, RG316DS, M17/151, M17/152, Times RD-316



APPLIED ENGINEERING PRODUCTS

(203) 776-2813 • FAX (203) 776-8294

www.aepconnectors.com • aepsales@aepconnectors.com

SLB Bulkhead Mounted Cable Jacks

Click on part number to go directly to cable assembly instructions

Straight Jacks

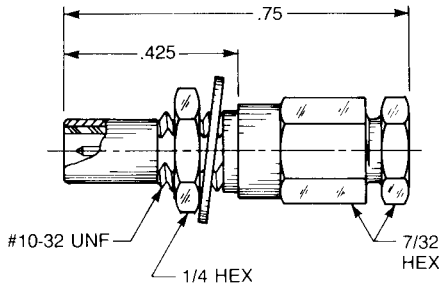

Straight Male Bulkhead Cable Jack

Clamp type for flexible cable:
3003-1551-0XX (Gold plated)
3003-7551-0XX (Nickel plated)

Solder-clamp for semi-rigid cable:
3003-1541-0XX (Gold plated)
3003-7541-0XX (Nickel plated)

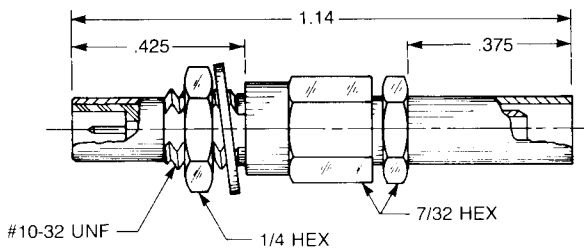

Straight Male Bulkhead Cable Jack

Crimp type for flexible cable:
3003-1571-0XX (Gold plated)
3003-7571-0XX (Nickel plated)

Right Angle Jacks

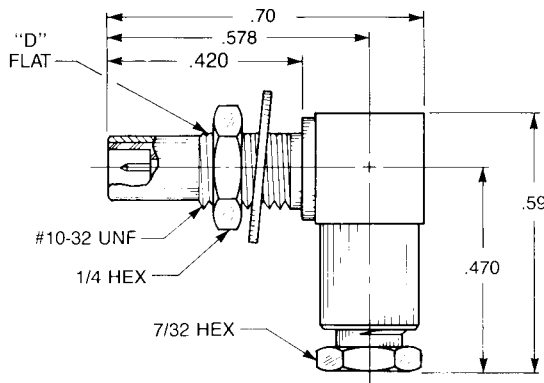

Right Angle Male Bulkhead Cable Jack

Clamp type for flexible cable:
3006-1551-0XX (Gold plated)
3006-7551-0XX (Nickel plated)

Solder-clamp for semi-rigid cable:
3006-1541-0XX (Gold plated)
3006-7541-0XX (Nickel plated)

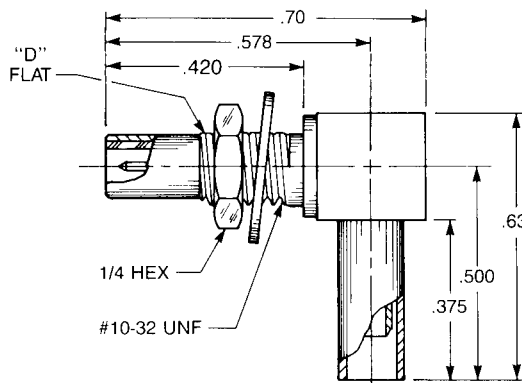

Right Angle Male Bulkhead Cable Jack

Crimp type for flexible cable:
3106-1521-0XX (Gold plated)
3106-7521-0XX (Nickel plated)

Substitute the appropriate cable group number for "XX" when ordering:

GROUP	CABLE TYPES	GROUP	CABLE TYPES	GROUP	CABLE TYPES
02	RG178, RG196, M17/93, M17/169	05	RG178DS, RG196DS	10	.085" semi-rigid, RG405, M17/133
03	RG174, RG179, RG316, M17/113, M17/119, M17/172, M17/189	09	.141" semi-rigid, RG 402M17/130	19	RG174DS, RG316DS, M17/151, M17/152, Times RD-316

SLB Bulkhead Jack Receptacles

Straight Jacks

Straight Male Bulkhead Jack Receptacle

- Solder pot contact
- Rear mount

3004-1511-000 (Gold plated)
3004-7511-000 (Nickel plated)

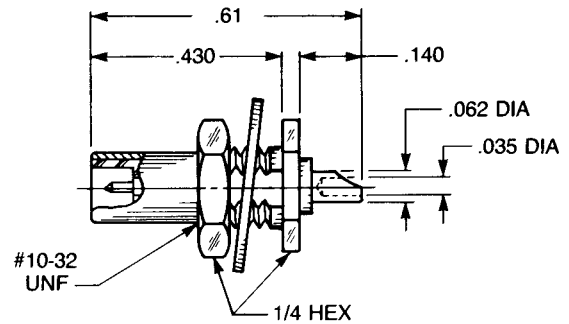

Straight Male Bulkhead Jack Receptacle

- Solder pot contact
- Front mount

3019-1511-000 (Gold plated)
3019-7511-000 (Nickel plated)

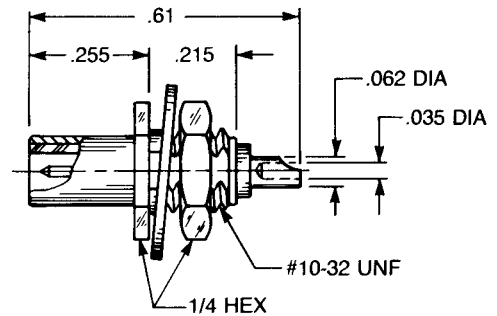

Straight Male Bulkhead Jack Receptacle

- Solder pot contact
- Recessed front mount

3014-1511-000 (Gold plated)
3014-7511-000 (Nickel plated)

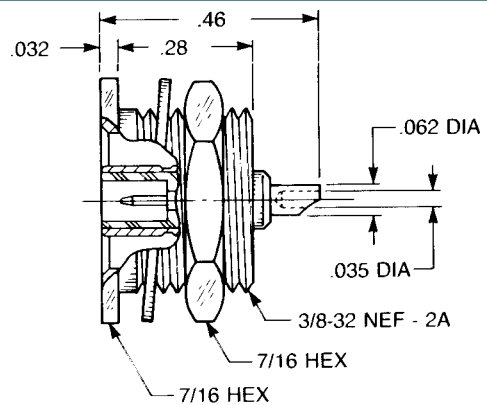

Right Angle Jacks

Right Angle Male Bulkhead Jack Receptacle

- Solder pot contact
- Front mount

3012-1511-000 (Gold plated)
3012-7511-000 (Nickel plated)

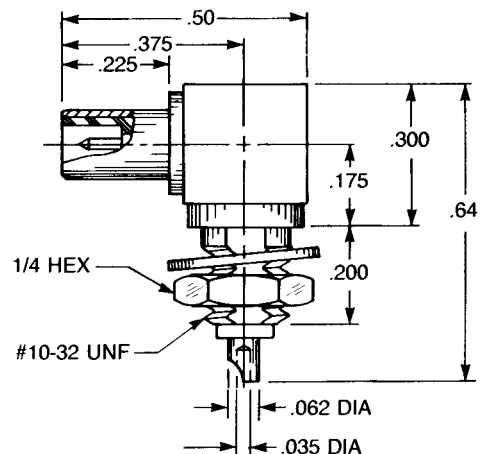

(All fit .093" max panel thickness)



APPLIED ENGINEERING PRODUCTS

(203) 776-2813 • FAX (203) 776-8294

www.aepconnectors.com • aepsales@aepconnectors.com

SLB Bulkhead Plug Receptacles

Straight Plugs

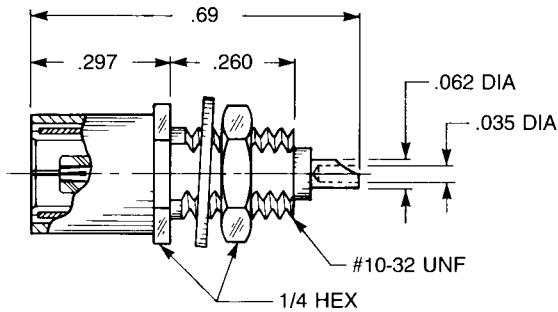

Straight Female Bulkhead Plug Receptacle

- Solder pot contact
- Front mount

3017-1511-000 (Gold plated)
3017-7511-000 (Nickel plated)

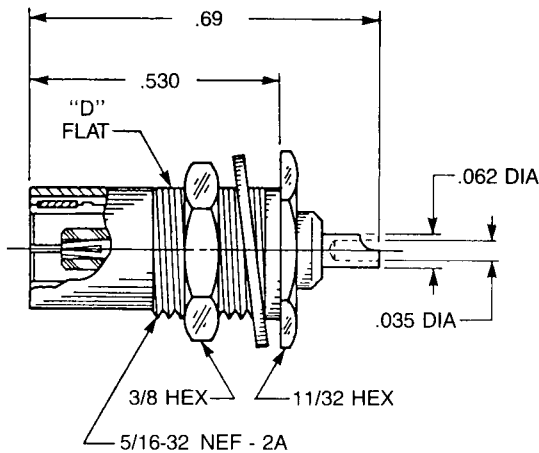

Straight Female Bulkhead Plug Receptacle

- Solder pot contact
- Rear mount

3048-1511-000 (Gold plated)
3048-7511-000 (Nickel plated)

Right Angle Plugs

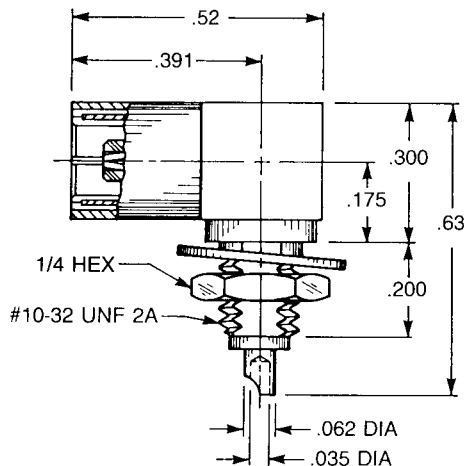

Right Angle Female Bulkhead Plug Receptacle

- Solder pot contact
- Front mount

3097-1511-000 (Gold plated)
3097-7511-000 (Nickel plated)

(All fit .093" max panel thickness)



APPLIED ENGINEERING PRODUCTS

(203) 776-2813 • FAX (203) 776-8294

www.aepconnectors.com • aepsales@aepconnectors.com

SLB P.C. Board Receptacles

Straight Jacks

Straight Male Jack Receptacle

3009-1511-000 (Gold plated)
3009-7511-000 (Nickel plated)

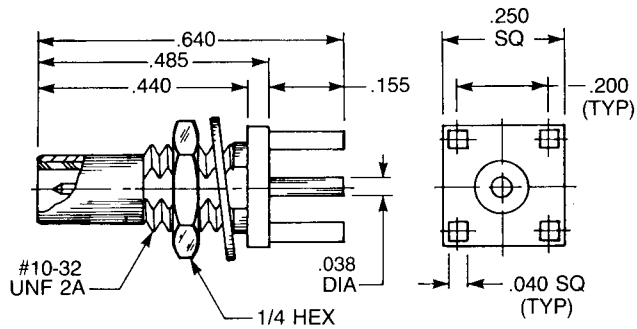
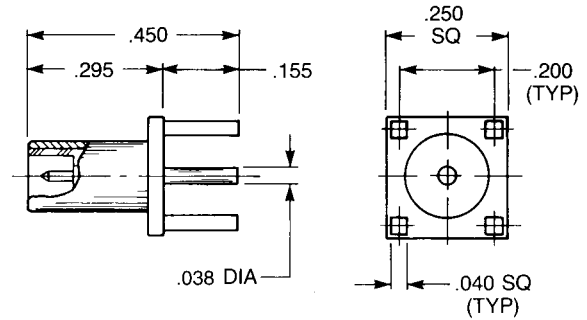

Bulkhead Mounted Straight Male Jack P.C. Board Receptacle

3109-1511-000 (Gold plated)
3109-7511-000 (Nickel plated)

Straight Plug

Straight Female Plug Receptacle

3025-1511-000 (Gold plated)
3025-7511-000 (Nickel plated)

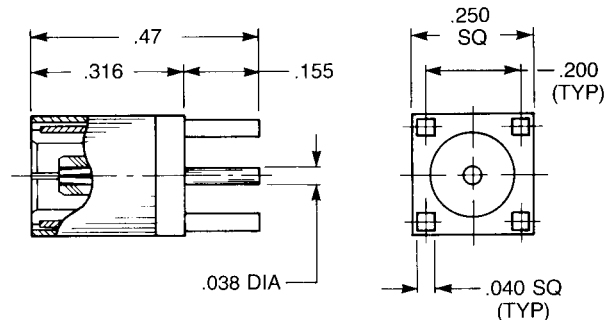

SLB P.C. Board Receptacles

Right Angle Jacks

Right Angle Male Jack Receptacle

A	B	C	D
.43	.15	.50	.38
3010-1511-000		(Gold plated)	
3010-7511-000		(Nickel plated)	

A	B	C	D
.50	.215	.56	.437
3010-1511-003		(Gold plated)	
3010-7511-003		(Nickel plated)	

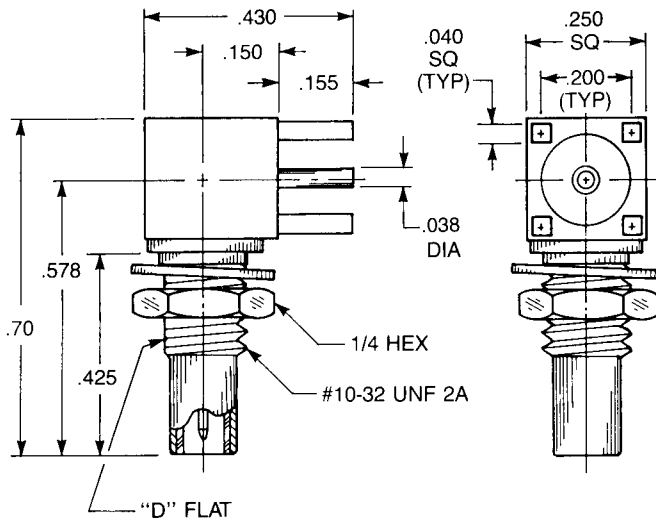
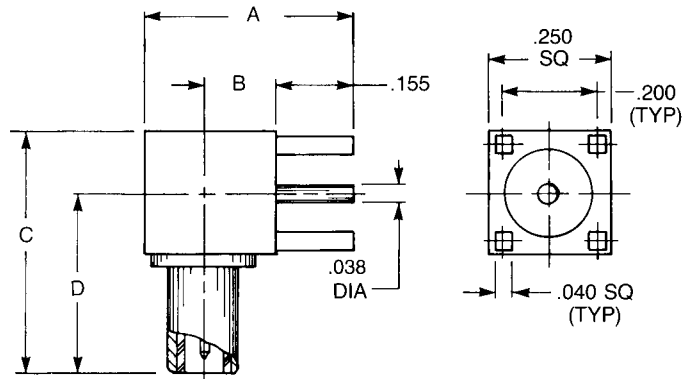

Bulkhead Mounted Right Angle Male Jack P.C. Board Receptacle

3110-1511-000 (Gold plated)
3110-7511-000 (Nickel plated)

Right Angle Plug

Right Angle Female Plug Receptacle

3042-1511-000 (Gold plated)
3042-7511-000 (Nickel plated)

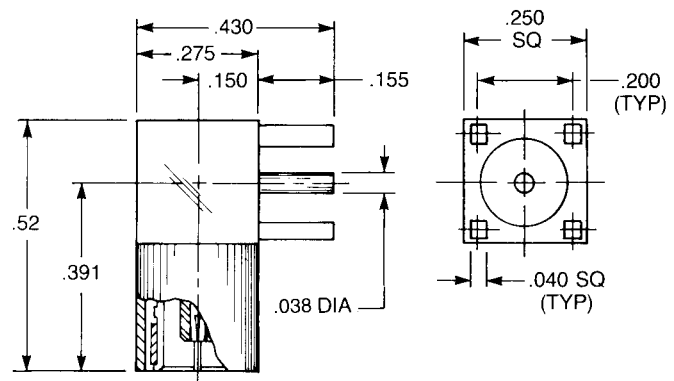

SLB Float Mount / Blind Mate

Introduction

This series of SLB connectors with float mount hardware can provide a low-cost alternative to other blind-mate connector systems in applications below 4 GHz.

The radial float of the panel mounted connectors, combined with the closed-entry mating end hood of the plugs, allows the mating pairs to be misaligned up to .025" without damage occurring during mating. Since the axial float is not spring-loaded, panel-to-panel separation should be maintained within $\pm .010$ " of the recommended dimension when mated.

Mating force per connector pair is 3 pounds maximum, and unmating force is 8 ounces minimum per pair. External actuators, such as levers, guide rails, or jackscrews, should be incorporated in applications requiring simultaneous mating of multiple connector pairs. This is particularly important when one side is mounted to a P.C. board.

Only one side of the mating [pair should be float mounted; float mounting both connectors in a mating pair will allow a radial float that exceeds the plug mating end hood's ability to guide the jack into proper orientation.

This style of float mounting is not recommended for applications which undergo vibration while powered. Vibration of this style of float mounting can cause intermittent ground interrupts. For SLB connectors with vibration-proof float mounts, see page 20.

Mating Detail

MATING DETAIL, 3025-1511-005 AND 3003-1551-703

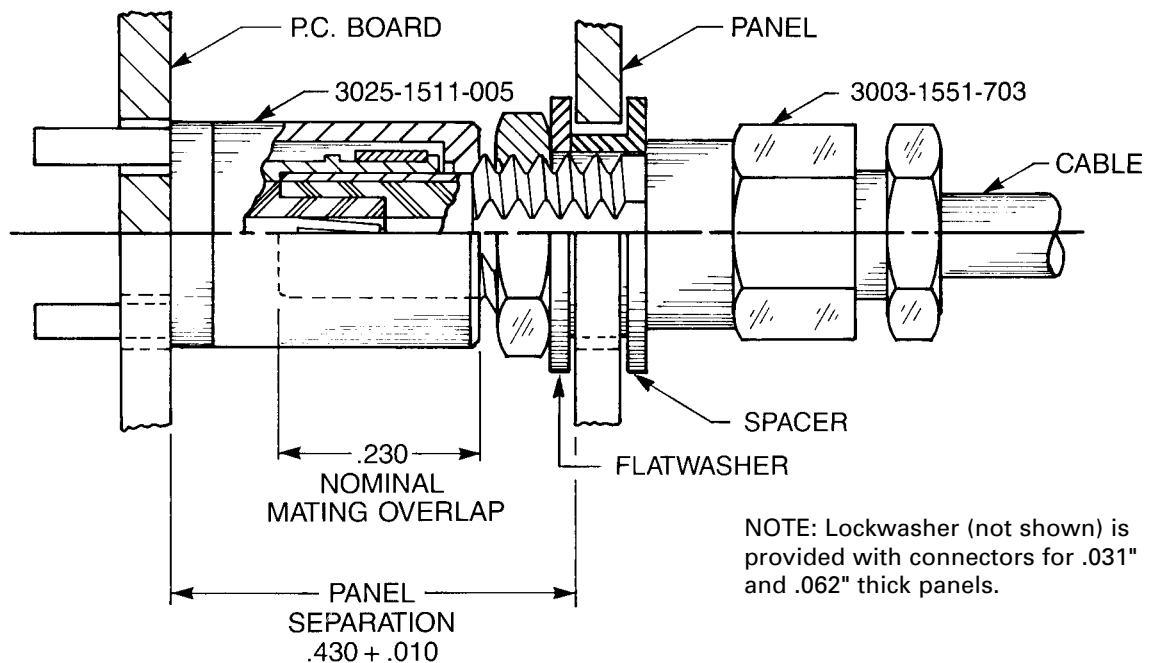

To determine panel separation: Add projection from panel or P.C. board for each connector in the mating pair and subtract the nominal mating overlap (.230"). the projection for each connector is shown on the product pages, and is measured with all axial float loaded toward the panel. Axial float is .008" for all connectors.

Radial float: Because these connectors provide a maximum .025" radial float, panels can be drilled up to .255" mounting hole diameter. Center-to-center tolerances of drilled panel holes should be subtracted from this diameter to keep within maximum float tolerances.

SLB Float Mounted Cable Plugs

Click on part number to go directly to cable assembly instructions

Clamp Type for Flexible Cable or Solder-Clamp for Semi-Rigid Cable

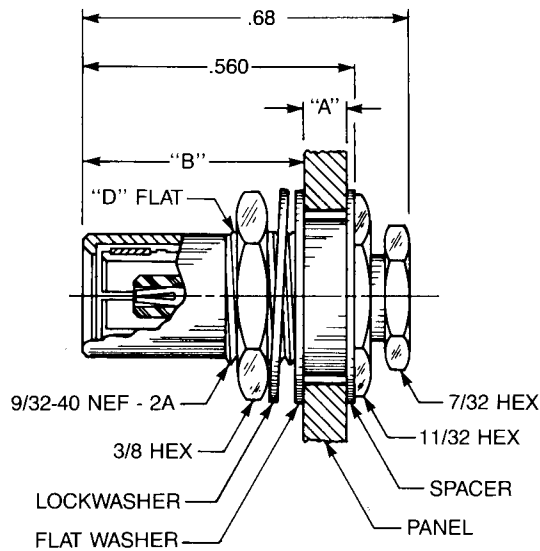

Bulkhead Mounted Straight Female Cable Plug Float Mount/Blind Mate

- Closed-entry mating end hood

Dim. A	Dim. B	Clamp type for flexible cable:
.031	.500	3028-1551-5XX (Gold plated) 3028-7551-5XX (Nickel plated)
.062	.469	3028-1551-6XX (Gold plated) 3028-7551-6XX (Nickel plated)
.093	.438	3028-1551-7XX (Gold plated) 3028-7551-7XX (Nickel plated)

Dim. A	Dim. B	Solder-clamp for semi-rigid cable:
.031	.500	3028-1541-5XX (Gold plated) 3028-7541-5XX (Nickel plated)
.062	.469	3028-1541-6XX (Gold plated) 3028-7541-6XX (Nickel plated)
.093	.438	3028-1541-7XX (Gold plated) 3028-7541-7XX (Nickel plated)

Crimp Type for Flexible Cable

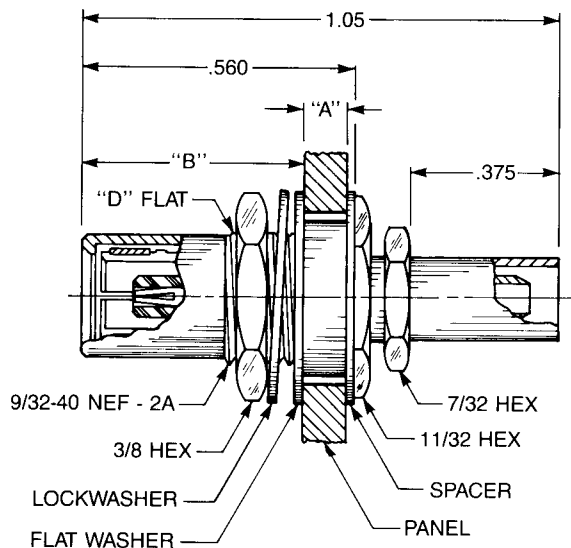

Bulkhead Mounted Straight Female Cable Plug Float Mount/Blind Mate

- Closed-entry mating end hood

Dim. A	Dim. B	Crimp type for flexible cable:
.031	.500	3028-1571-5XX (Gold plated) 3028-7571-5XX (Nickel plated)
.062	.469	3028-1571-6XX (Gold plated) 3028-7571-6XX (Nickel plated)
.093	.438	3028-1571-7XX (Gold plated) 3028-7571-7XX (Nickel plated)

Substitute the appropriate cable group number for "XX" when ordering:

GROUP	CABLE TYPES	GROUP	CABLE TYPES	GROUP	CABLE TYPES
02	RG178, RG196, M17/93, M17/169	05	RG178DS, RG196DS	10	.085" semi-rigid, RG405, M17/133
03	RG174, RG179, RG316, M17/113, M17/119, M17/172, M17/189	09	.141" semi-rigid, RG 402M17/130	19	RG174DS, RG316DS, M17/151, M17/152, Times RD-316

SLB Float Mounted Bulkhead Jacks

Click on part number to go directly to cable assembly instructions

Clamp Type for Flexible Cable or Solder-Clamp for Semi-Rigid Cable

Float Mount Straight Male Bulkhead Cable Jack

Dim. A	Dim. B	Clamp type for flexible cable:
.031	.365	3003-1551-5XX (Gold plated) 3003-7551-5XX (Nickel plated)
.062	.334	3003-1551-6XX (Gold plated) 3003-7551-6XX (Nickel plated)
.093	.303	3003-1551-7XX (Gold plated) 3003-7551-7XX (Nickel plated)

Dim. A	Dim. B	Solder-clamp for semi-rigid cable:
.031	.365	3003-1541-5XX (Gold plated) 3003-7541-5XX (Nickel plated)
.062	.334	3003-1541-6XX (Gold plated) 3003-7541-6XX (Nickel plated)
.093	.303	3003-1541-7XX (Gold plated) 3003-7541-7XX (Nickel plated)

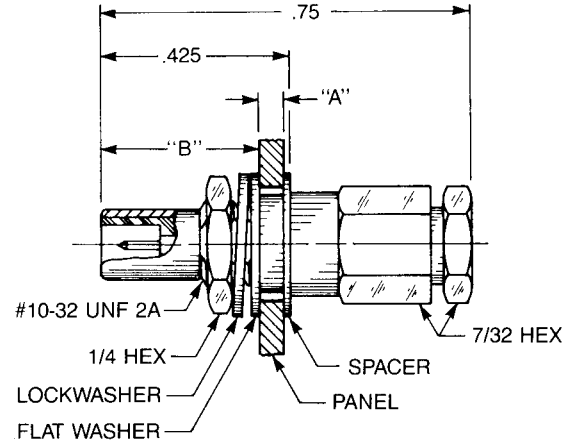

Crimp Type for Flexible Cable

Float Mount Straight Male Bulkhead Cable Jack

Dim. A	Dim. B	Crimp type for flexible cable:
.031	.365	3003-1571-5XX (Gold plated) 3003-7571-5XX (Nickel plated)
.062	.334	3003-1571-6XX (Gold plated) 3003-7571-6XX (Nickel plated)
.093	.303	3003-1571-7XX (Gold plated) 3003-7571-7XX (Nickel plated)

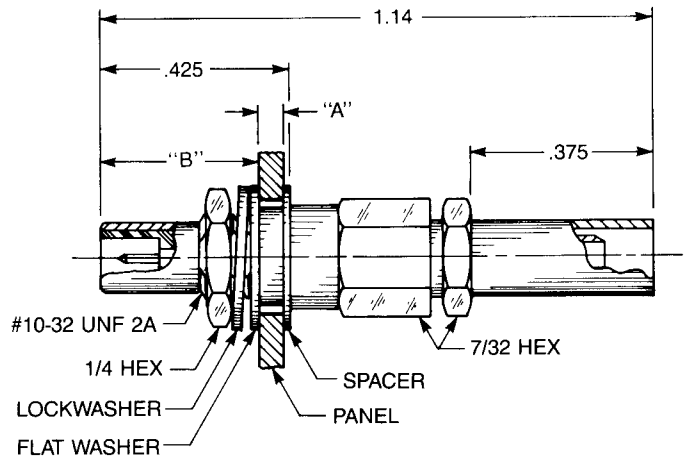

Substitute the appropriate cable group number for "XX" when ordering:

GROUP	CABLE TYPES	GROUP	CABLE TYPES	GROUP	CABLE TYPES
02	RG178, RG196, M17/93, M17/169	05	RG178DS, RG196DS	10	.085" semi-rigid, RG405, M17/133
03	RG174, RG179, RG316, M17/113, M17/119, M17/172, M17/189	09	.141" semi-rigid, RG 402M17/130	19	RG174DS, RG316DS, M17/151, M17/152, Times RD-316

SLB Float Mounted Bulkhead Jacks

Click on part number to go directly to cable assembly instructions

Clamp Type for Flexible Cable or Solder-Clamp for Semi-Rigid Cable

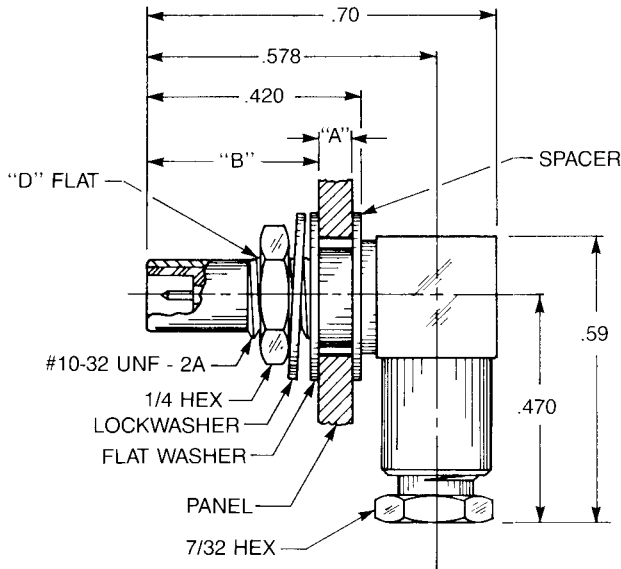

Float Mount Right Angle Male Bulkhead Cable Jack

Dim. A	Dim. B	Clamp type for flexible cable:
.031	.360	3006-1551-5XX (Gold plated) 3006-7551-5XX (Nickel plated)
.062	.329	3006-1551-6XX (Gold plated) 3006-7551-6XX (Nickel plated)
.093	.298	3006-1551-7XX (Gold plated) 3006-7551-7XX (Nickel plated)

Dim. A	Dim. B	Solder-clamp for semi-rigid cable:
.031	.360	3006-1541-5XX (Gold plated) 3006-7541-5XX (Nickel plated)
.062	.329	3006-1541-6XX (Gold plated) 3006-7541-6XX (Nickel plated)
.093	.298	3006-1541-7XX (Gold plated) 3006-7541-7XX (Nickel plated)

Crimp Type for Flexible Cable

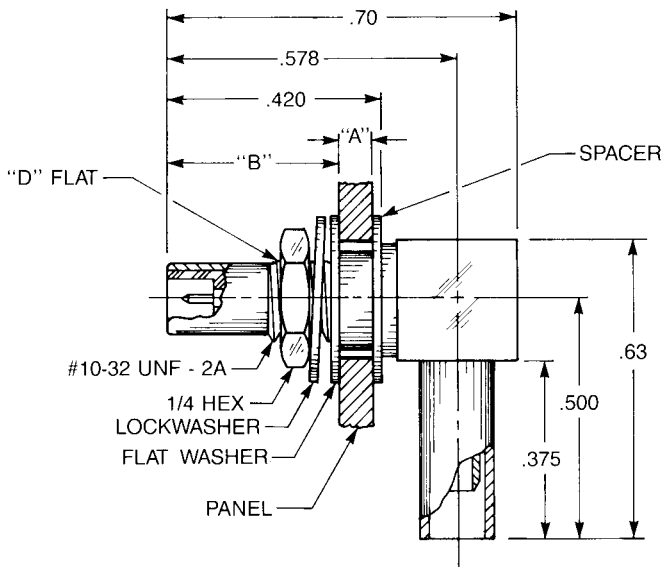

Float Mount Right Angle Male Bulkhead Cable Jack

Dim. A	Dim. B	Crimp type for flexible cable:
.031	.360	3106-1521-5XX (Gold plated) 3106-7521-5XX (Nickel plated)
.062	.329	3106-1521-6XX (Gold plated) 3106-7521-6XX (Nickel plated)
.093	.298	3106-1521-7XX (Gold plated) 3106-7521-7XX (Nickel plated)

Substitute the appropriate cable group number for "XX" when ordering:

GROUP	CABLE TYPES	GROUP	CABLE TYPES	GROUP	CABLE TYPES
02	RG178, RG196, M17/93, M17/169	05	RG178DS, RG196DS	10	.085" semi-rigid, RG405, M17/133
03	RG174, RG179, RG316, M17/113, M17/119, M17/172, M17/189	09	.141" semi-rigid, RG 402M17/130	19	RG174DS, RG316DS, M17/151, M17/152, Times RD-316



APPLIED ENGINEERING PRODUCTS

(203) 776-2813 • FAX (203) 776-8294

www.aepconnectors.com • aepsales@aepconnectors.com

SLB Float Mounted Jack Receptacles

Rear Mount

Float Mount Straight Male Bulkhead Jack Receptacle

- Solder pot contact
- Rear mount

Dim. A	Dim. B	Part Number	Plating
.031	.370	3004-1511-500	(Gold plated)
		3004-7511-500	(Nickel plated)
.062	.339	3004-1511-600	(Gold plated)
		3004-7511-600	(Nickel plated)
.093	.308	3004-1511-700	(Gold plated)
		3004-7511-700	(Nickel plated)

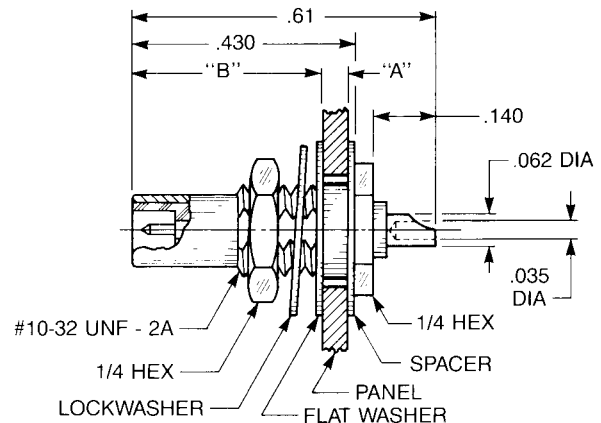

Front Mount

Float Mount Straight Male Bulkhead Jack Receptacle

- Solder pot contact
- Front mount

Dim. A	Part Number	Plating
.031	3019-1511-500	(Gold plated)
	3019-7511-500	(Nickel plated)
.062	3019-1511-600	(Gold plated)
	3019-7511-600	(Nickel plated)
.093	3019-1511-700	(Gold plated)
	3019-7511-700	(Nickel plated)

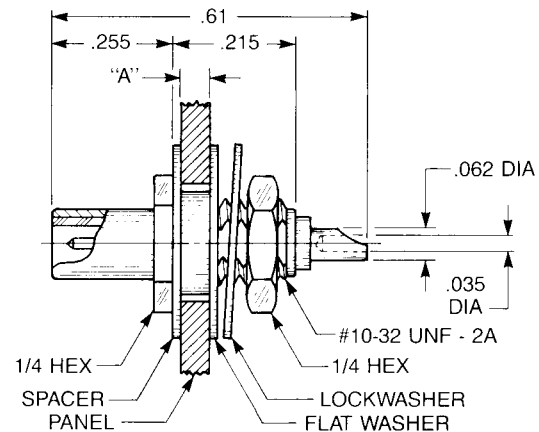

Recessed Mount

Float Mount Straight Male Bulkhead Jack Receptacle

- Solder pot contact
- Recessed front mount

Dim. A	Part Number	Plating
.031	3014-1511-500	(Gold plated)
	3014-7511-500	(Nickel plated)
.062	3014-1511-600	(Gold plated)
	3014-7511-600	(Nickel plated)
.093	3014-1511-700	(Gold plated)
	3014-7511-700	(Nickel plated)

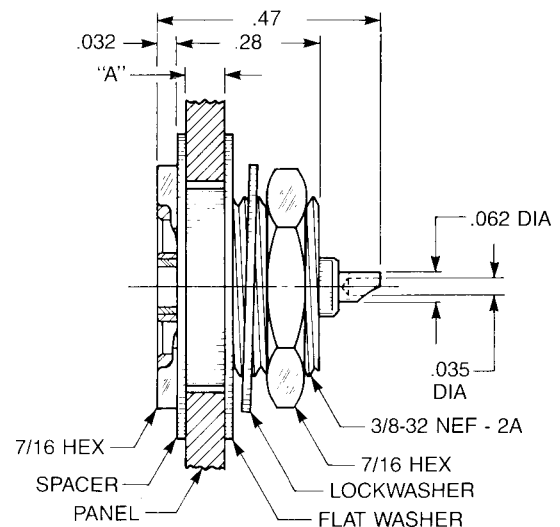

SLB Float Mounted Plug Receptacles

Front Mount

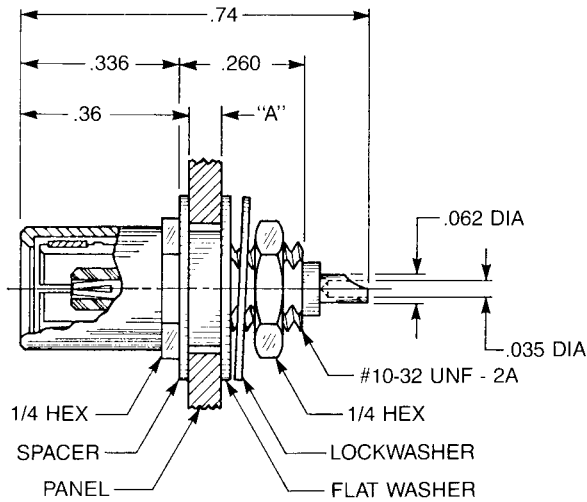

Float Mount Straight Female Bulkhead Plug Receptacle

- Solder pot contact
- Front mount
- Closed-entry mating end hood

Dim. A

.031	3017-1511-500	(Gold plated)
	3017-7511-500	(Nickel plated)
.062	3017-1511-600	(Gold plated)
	3017-7511-600	(Nickel plated)
.093	3017-1511-700	(Gold plated)
	3017-7511-700	(Nickel plated)

Rear Mount

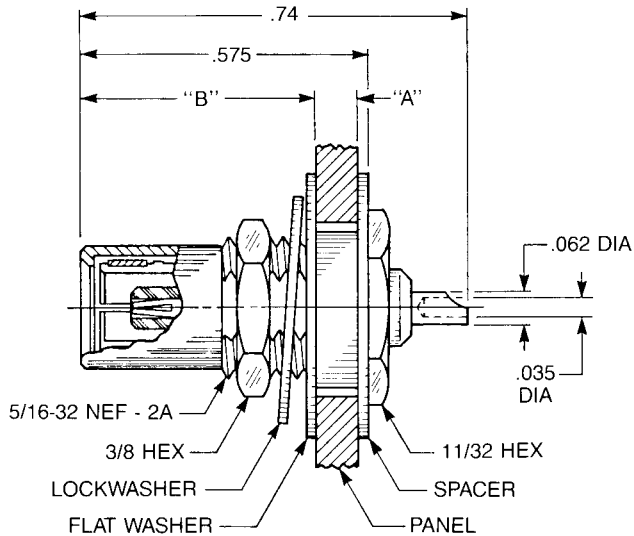

Float Mount Straight Female Bulkhead Plug Receptacle

- Solder pot contact
- Rear mount
- Closed-entry mating end hood

Dim. A Dim. B

.031	.515	3048-1511-500	(Gold plated)
		3048-7511-500	(Nickel plated)
.062	.484	3048-1511-600	(Gold plated)
		3048-7511-600	(Nickel plated)
.093	.453	3048-1511-700	(Gold plated)
		3048-7511-700	(Nickel plated)



SLB Float Mounted PCB Receptacles

Straight Jack

Float Mount Straight Male Jack P.C. Board Receptacle

Dim. A	Dim. B	Part Number	Plating
.031	.380	3109-1511-500	Gold plated
		3109-7511-500	Nickel plated
.062	.349	3109-1511-600	Gold plated
		3109-7511-600	Nickel plated
.093	.318	3109-1511-700	Gold plated
		3109-7511-700	Nickel plated

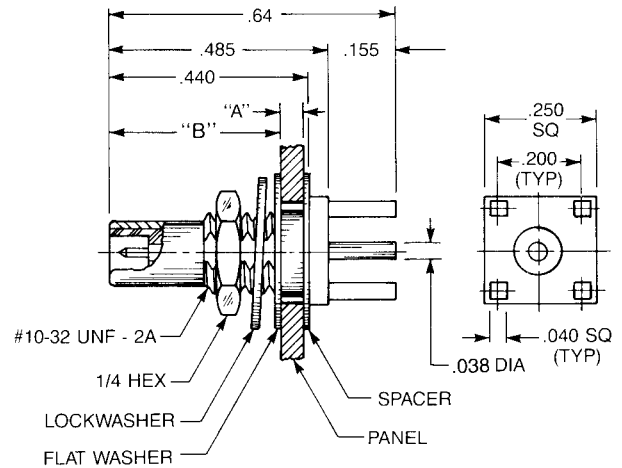

Right Angle Jack

Float Mount Right Angle Male Jack P.C. Board Receptacle

Dim. A	Dim. B	Part Number	Plating
.031	.365	3110-1511-500	Gold plated
		3110-7511-500	Nickel plated
.062	.334	3110-1511-600	Gold plated
		3110-7511-600	Nickel plated
.093	.303	3110-1511-700	Gold plated
		3110-7511-700	Nickel plated

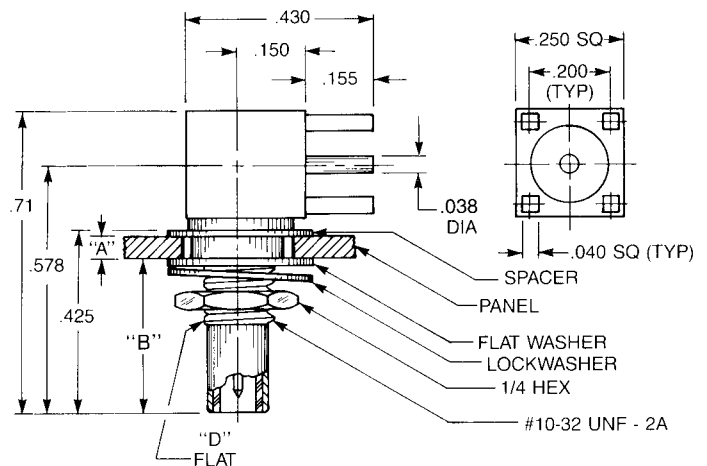

SLB Closed-Entry PCB Plugs

For use with float-mounted jacks

Straight Plug

Straight Female Plug P.C. Board Receptacle

- Closed-entry mating end hood

3025-1511-005 (Gold plated)

3025-7511-005 (Nickel plated)

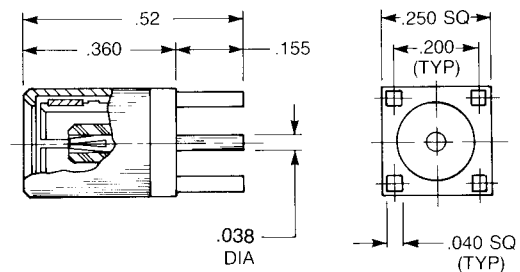

Right Angle Plug

Right Angle Female Plug P.C. Board Receptacle

- Closed-entry mating end hood

3042-1511-006 (Gold plated)

3042-7511-006 (Nickel plated)

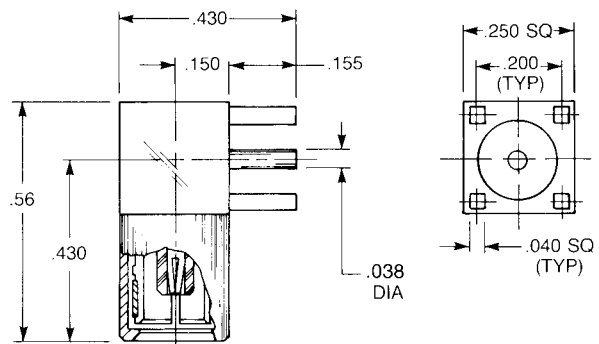

SLB Vibration-Proof Float Mounts

Introduction

AEP's vibration-proof float mounted connectors use a tempered spring washer within the mounting system for reliable grounding between the connector and the panel under vibration. This system, combined with closed-end mating hoods and contacts, allows the connectors a wide range of float while mating without damage to the connectors.

AEP vibration-proof float mount connectors meet appropriate performance requirements of MIL-PRF-39012. The items on the next page are only the most commonly-used configurations; vibration-proof mounting hardware can be provided with any bulkhead-mounted SLB plug or jack in this catalog. All connectors shown have gold-plated, captive contacts and gold-plated bodies.

How They Work

Standard Float Mounts

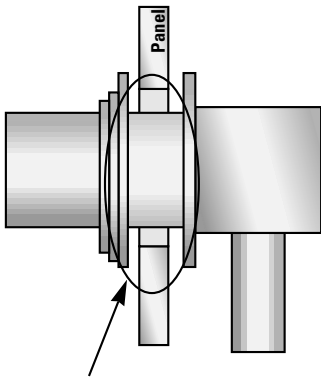

Connectors that use shoulder washers as a float mount can, under vibration, intermittently become "suspended" in their mounting holes—resulting in loss of electrical contact between body and panel.
(Proportions exaggerated to illustrate detail.)

AEP Vibration-Proof Float Mounts

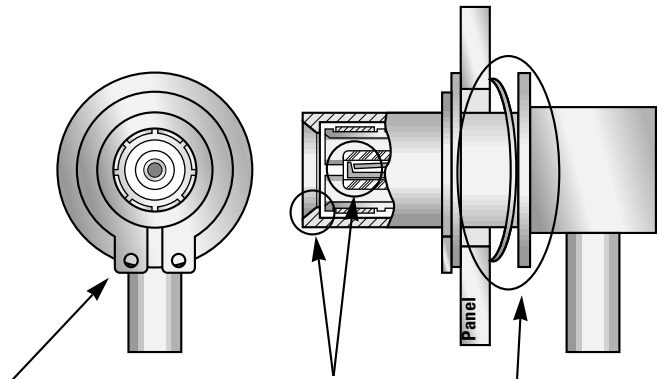

The Truarc retaining provides almost 360° of contact with its retaining groove, rather than the 10–20° of contact of C-rings or E-rings.

AEP's closed-entry mating end hood and center contact resist damage from misaligned mating connectors.

The spring washer ensures consistent grounding under vibration.

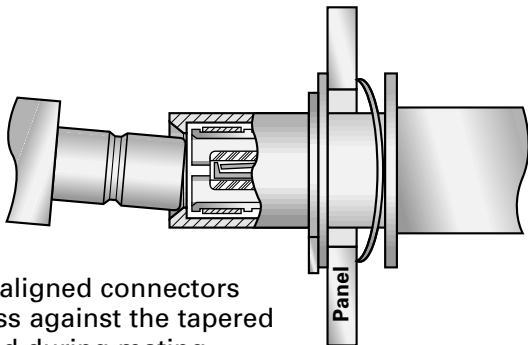

Misaligned connectors press against the tapered hood during mating...

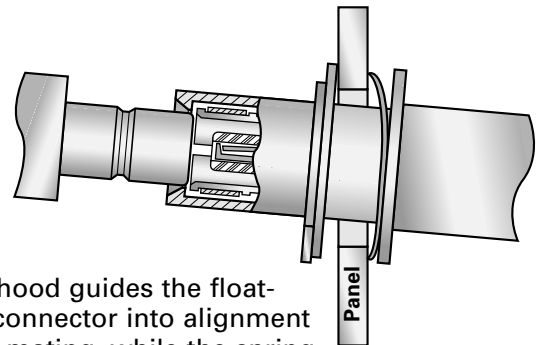

...and the hood guides the float-mounted connector into alignment for proper mating, while the spring washer deflects to accommodate the angular and radial movement with no loss of grounding.

SLB Vibration-Proof Float Mounted Plugs

Click on part number to go directly to cable assembly instructions

Straight Plug

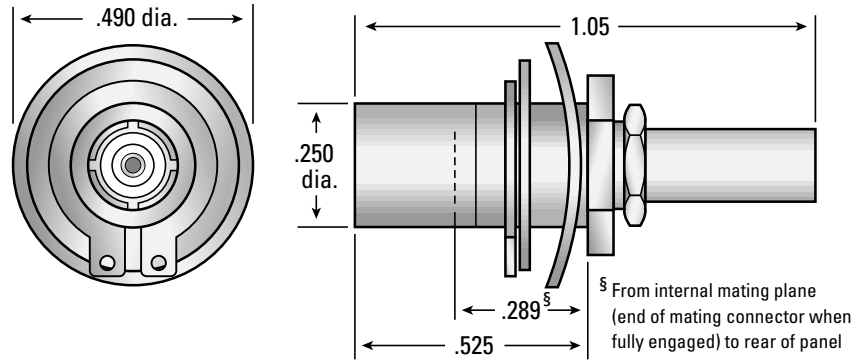

PANEL THICKNESS	AEP P/N
.050	3096-1571-OXX*
.093	3096-1571-2XX*

Right Angle Plug

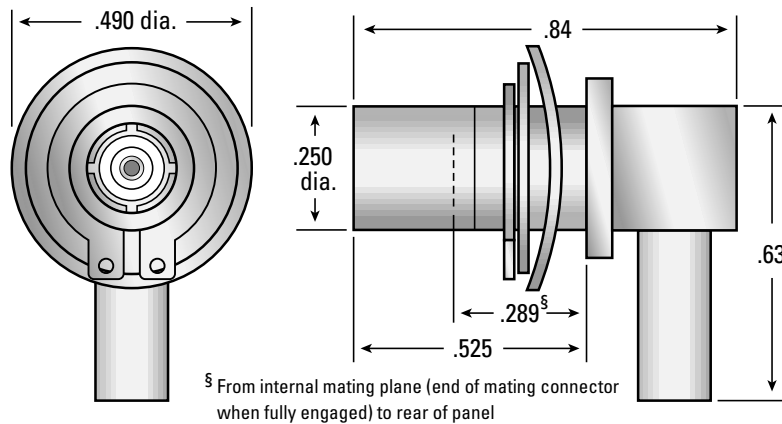

PANEL THICKNESS	AEP P/N
.050	3026-1521-OXX*
.093	3026-1521-2XX*

*Substitute the appropriate cable group number for "XX" when ordering:

GROUP	CABLE TYPES	GROUP	CABLE TYPES
02	RG178, RG196, M17/93, M17/169	05	RG178DS, RG196DS
03	RG174, RG179, RG316, M17/113, M17/119, M17/172, M17/189	19	RG174DS, RG316DS, M17/152, Times RD316

SLB Adapters

Straight Jack to jack, Bulkhead Mounted

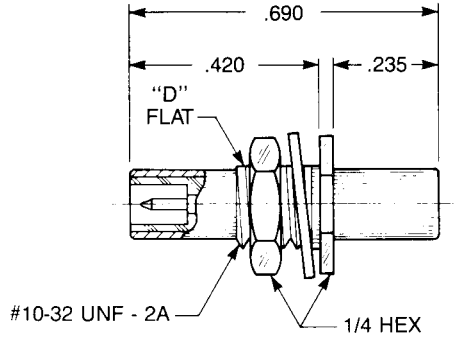

Bulkhead Mounted Straight Male Jack to Jack Adapter

5252-1501-000 (Gold plated)
5252-7501-000 (Nickel plated)

Straight Jack to jack, Float Mounted

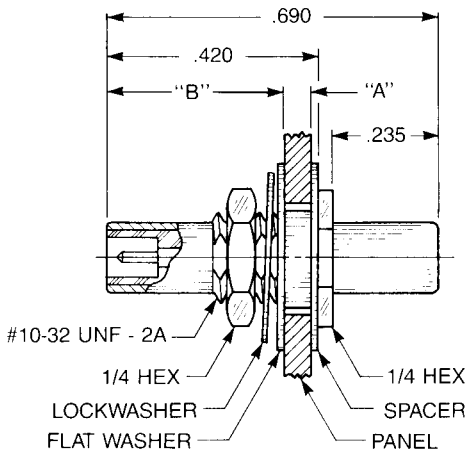

Float Mount Straight Male Jack To Jack Adapter

- Connects two plugs

Dim. A	Dim. B	
.031	.360	5252-1501-500 (Gold plated)
		5252-7501-500 (Nickel plated)
.062	.329	5252-1501-600 (Gold plated)
		5252-7501-600 (Nickel plated)
.093	.298	5252-1501-700 (Gold plated)
		5252-7501-700 (Nickel plated)



Cable Assembly Instructions

Clamp type connectors for flexible cable

Straight Connectors—Flexible Cable

Parts list

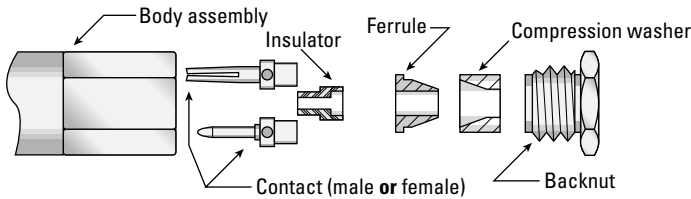

1

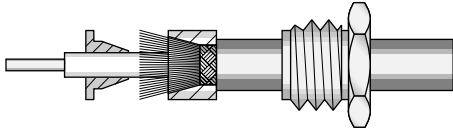

- Trim cable per trim code below; tin end of center conductor.
- Slide backnut onto cable. Slide compression washer onto cable in the orientation shown until it stops against cable jacket.
- Flare cable braid by rotating dielectric and slide ferrule under braid.

2

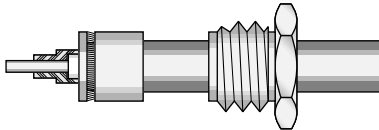

- Press ferrule against compression washer.
- Trim excess braid flush with outer diameter of compression washer and ferrule.
- Assemble insulator over cable center conductor and dielectric.

3

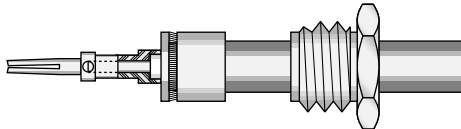

- Assemble contact onto cable center conductor.
- Solder contact to center conductor by heating rear of contact (do not feed additional solder through inspection hole in contact).

4

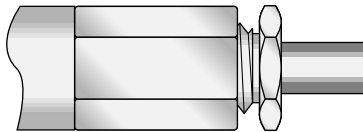

- Insert cable assembly into body assembly. Tighten to 90–100 inch-ounces torque. (Hold cable/hardware assembly stationary and rotate body when tightening.)

Cable Trim Dimensions

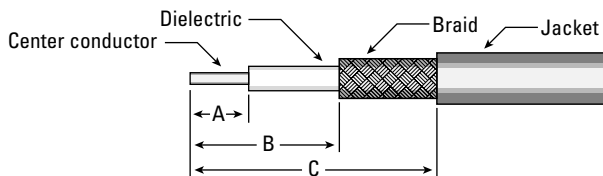

CONNECTOR TYPE	A	B	C
STRAIGHT CONNECTORS	.080	.120	.240
RIGHT ANGLE CONNECTORS	.080	.180	.300

Right Angle Connectors—Flexible Cable

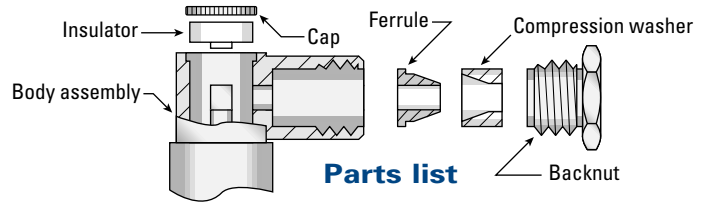

1

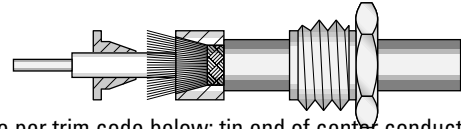

- Trim cable per trim code below; tin end of center conductor.
- Slide backnut onto cable. Slide compression washer onto cable in the orientation shown until it stops against cable jacket.
- Flare cable braid by rotating dielectric and slide ferrule under braid.

2

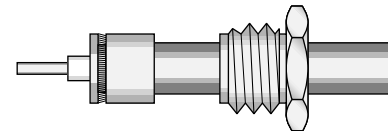

- Press ferrule against compression washer.
- Trim excess braid flush with outer diameter of compression washer and ferrule.
- Assemble insulator over cable center conductor and dielectric.

3

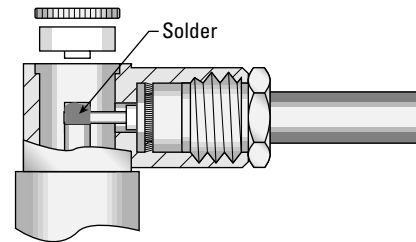

- Insert cable assembly into body assembly. Tighten to 90–100 inch-ounces torque. (Hold cable/hardware assembly stationary and rotate body when tightening.)
- Solder center conductor into notch in rear of contact with .025–.032" diameter chisel-tip soldering iron.
- Solder should cover center conductor, but not extend over top of notch in contact, or exceed contact diameter.

4

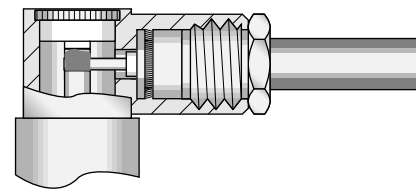

- Place insulator in body cavity, and press cap into place. Properly assembled cap will be slightly below end of body assembly.

Cable Assembly Instructions

Crimp type connectors for flexible cable

Straight Connectors—Flexible Cable

Parts list

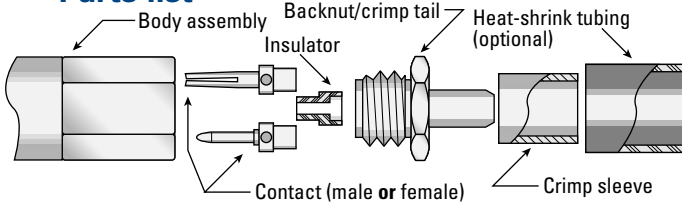

1

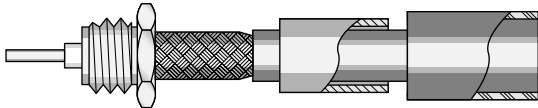

- Trim cable per trim code below; tin end of center conductor.
- Slide heat-shrink tubing and crimp sleeve over cable.
- Flare cable braid by rotating dielectric and slide cable into crimp tail.

2

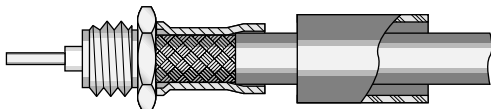

- Position cable so braid touches rear of back nut.
- Slide crimp sleeve forward to touch rear of back nut.
- Crimp braid with appropriate die size from chart below.

3

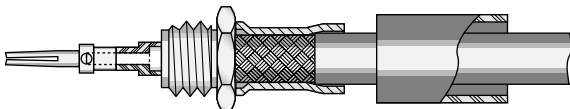

- Assemble insulator and contact onto cable dielectric and center conductor.
- Solder contact to center conductor by heating rear of contact (do not feed additional solder through inspection hole in contact).

4

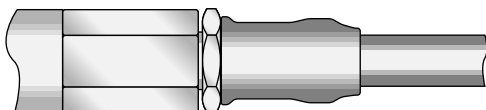

- Insert cable assembly into body assembly. Tighten to 90–100 inch-ounces torque. (Hold cable/hardware assembly stationary and rotate body when tightening.)
- Slide shrink tubing over crimp sleeve and shrink to fit.

Cable Trim Dimensions

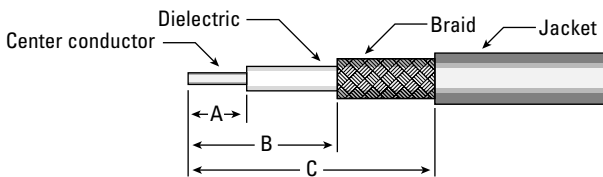

CONNECTOR TYPE	A	B	C
STRAIGHT CONNECTORS	.100	.430	.700
RIGHT ANGLE CONNECTORS	.070	.200	.450

Right Angle Connectors—Flexible Cable

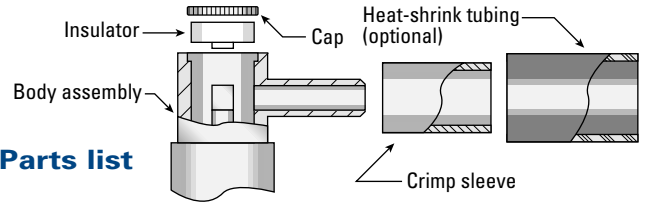

1

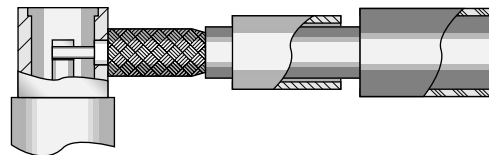

- Trim cable per trim code below; tin end of center conductor.
- Slide heat-shrink tubing and crimp sleeve over cable.
- Flare cable braid by rotating dielectric and slide cable into crimp tail.

2

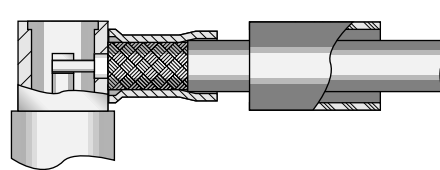

- Position cable so braid touches rear of body assembly.
- Slide crimp sleeve forward to touch rear of body assembly.
- Crimp braid with appropriate die size from chart below.

3

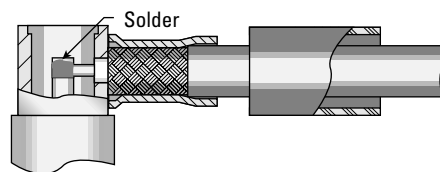

- Solder center conductor into notch in rear of contact with .025–.032" diameter chisel-tip soldering iron.
- Solder should cover center conductor, but not extend over top of notch in contact, or exceed contact diameter.

4

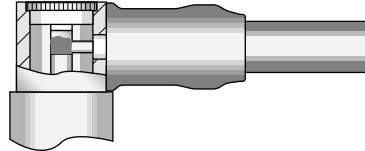

- Place insulator in body cavity, and press cap into place. Properly assembled cap will be slightly below end of body assembly.
- Slide shrink tubing over crimp sleeve and shrink to fit.

Crimp Die Sizes

CABLE GROUP	HEX DIE SIZE
02	.105
03	.128
05	.128
19	.128



Cable Assembly Instructions

Solder-clamp connectors for semi-rigid cable

Straight Connectors—Semi-Rigid Cable

Parts list

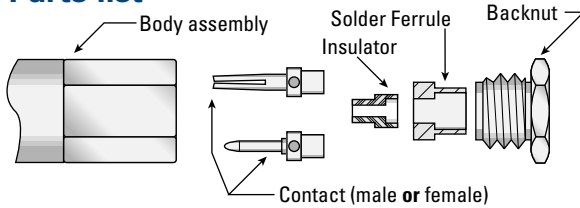

1

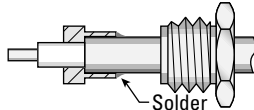

- Trim cable per trim code below; tin end of center conductor.
- Slide backnut over cable. Slide solder ferrule over cable until it stops against cable jacket.
- Solder cable jacket to ferrule.

2

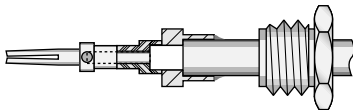

- Assemble insulator and contact onto cable dielectric and center conductor. If insulator is not flush against solder ferrule due to dielectric extrusion, retrim dielectric.
- Solder contact to center conductor by heating rear of contact (do not feed additional solder through inspection hole in contact).

3

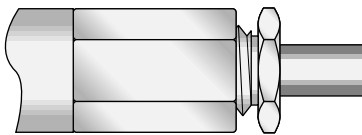

- Insert cable assembly into body assembly. Tighten to 90–100 inch-ounces torque. (Hold cable/hardware assembly stationary and rotate body when tightening.)

Right Angle Connectors—Semi-Rigid Cable

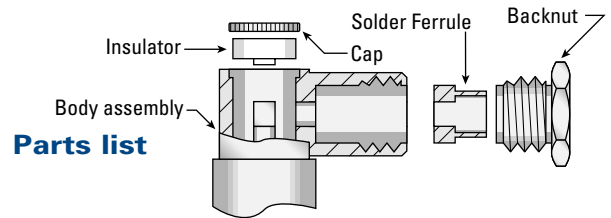

Parts list

1

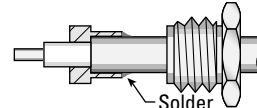

- Trim cable per trim code below; tin end of center conductor.
- Slide backnut over cable. Slide solder ferrule over cable until it stops against cable jacket.
- Solder cable jacket to ferrule.

2

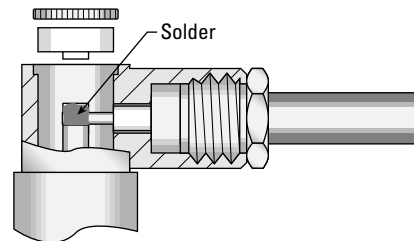

- Insert cable assembly into body assembly. Tighten to 90–100 inch-ounces torque. (Hold cable/hardware assembly stationary and rotate body when tightening.)
- Solder center conductor into notch in rear of contact with .025–.032" diameter chisel-tip soldering iron.
- Solder should cover center conductor, but not extend over top of notch in contact, or exceed contact diameter.

3

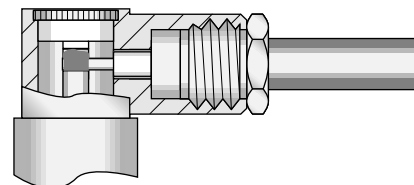

- Place insulator in body cavity, and press cap into place. Properly assembled cap will be slightly below end of body assembly.

Cable Trim Dimensions

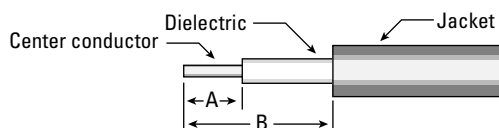

CONNECTOR TYPE	A	B
STRAIGHT CONNECTORS— .085" cable	.090	.170
STRAIGHT CONNECTORS— .141" cable	.105	.130
RIGHT ANGLE CONNECTORS	.110	.150



Mounting Dimensions

Bulkhead Receptacles

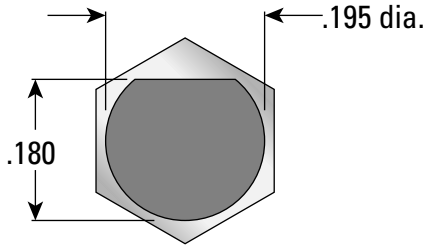

Flat of mounting surface is aligned with body hex as shown.

P.C. Board Receptacles

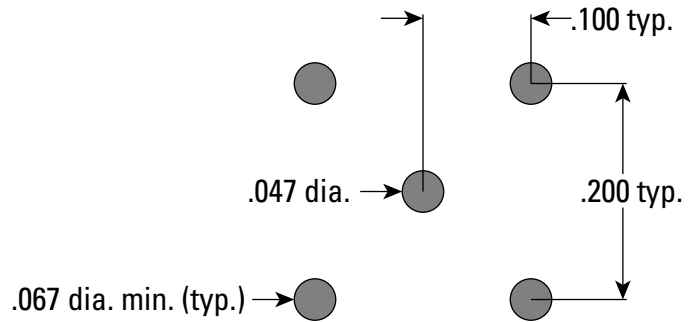

Assembly Tooling

Crimp tool

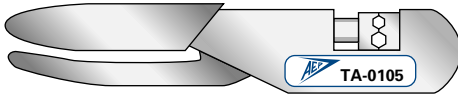

DESCRIPTION	AEP P/N
Crimp tool with .105" and .128" hex dies	TA-0105

Torque Wrench

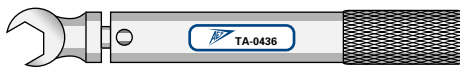

DESCRIPTION	AEP P/N
Torque wrench with 7/32" jaws for SLB connector backnuts; 95 inch-ounces torque	TA-0436

Capping Press

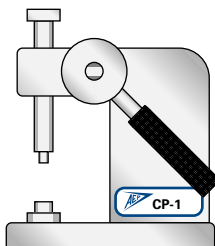

DESCRIPTION	AEP P/N
Capping tool (arbor press) with base for SLB right angle plugs	CP-1
Capping tool (arbor press) with base for SLB right angle jacks	CP-6

Index by Part Number

Click on any line below to go directly to the appropriate page

P/N	Page	P/N	Page	P/N	Page	P/N	Page
3001-1541-0XX*	6	3006-1541-7XX*	15	3028-1541-0XX*	5	3092-7511-003	13
3001-1551-0XX*	6	3006-1551-0XX*	7	3028-1541-5XX*	13	3096-1571-0XX	21
3001-1571-0XX*	6	3006-1551-5XX*	15	3028-1541-6XX*	13	3096-1571-2XX	21
3001-7541-0XX*	6	3006-1551-6XX*	15	3028-1541-7XX*	13	3097-1511-000	9
3001-7551-0XX*	6	3006-1551-7XX*	15	3028-1551-0XX*	5	3097-7511-000	9
3001-7571-0XX*	6	3006-7541-0XX*	7	3028-1551-5XX*	13	3105-1521-0XX*	4
3002-1541-0XX*	4	3006-7541-5XX*	15	3028-1551-6XX*	13	3105-7521-0XX*	4
3002-1551-0XX*	4	3006-7541-6XX*	15	3028-1551-7XX*	13	3106-1521-0XX*	7
3002-1571-0XX*	4	3006-7541-7XX*	15	3028-1571-0XX*	5	3106-1521-5XX*	15
3002-7541-0XX*	4	3006-7551-0XX*	7	3028-1571-5XX*	13	3106-1521-6XX*	15
3002-7551-0XX*	4	3006-7551-5XX*	15	3028-1571-6XX*	13	3106-1521-7XX*	15
3002-7571-0XX*	4	3006-7551-6XX*	15	3028-1571-7XX*	13	3106-7521-0XX*	7
3003-1541-0XX*	7	3006-7551-7XX*	15	3028-7541-0XX*	5	3106-7521-5XX*	15
3003-1541-5XX*	14	3009-1511-000	10	3028-7541-5XX*	13	3106-7521-6XX*	15
3003-1541-6XX*	14	3009-7511-000	10	3028-7541-6XX*	13	3106-7521-7XX*	15
3003-1541-7XX*	14	3010-1511-000	11	3028-7541-7XX*	13	3109-1511-000	10
3003-1551-0XX*	7	3010-1511-003	11	3028-7551-0XX*	5	3109-1511-500	18
3003-1551-5XX*	14	3010-7511-000	11	3028-7551-5XX*	13	3109-1511-600	18
3003-1551-6XX*	14	3010-7511-003	11	3028-7551-6XX*	13	3109-1511-700	18
3003-1551-7XX*	14	3012-1511-000	8	3028-7551-7XX*	13	3109-7511-000	10
3003-1571-0XX*	7	3012-7511-000	8	3028-7571-0XX*	5	3109-7511-500	18
3003-1571-5XX*	14	3014-1511-000	8	3028-7571-5XX*	13	3109-7511-600	18
3003-1571-6XX*	14	3014-1511-500	16	3028-7571-6XX*	13	3109-7511-700	18
3003-1571-7XX*	14	3014-1511-600	16	3028-7571-7XX*	13	3110-1511-000	11
3003-7541-0XX*	7	3014-1511-700	16	3029-1211-001	13	3110-1511-500	18
3003-7541-5XX*	14	3014-7511-000	8	3029-1211-002	13	3110-1511-600	18
3003-7541-6XX*	14	3014-7511-500	16	3029-1211-003	13	3110-1511-700	18
3003-7541-7XX*	14	3014-7511-600	16	3029-7211-001	13	3110-7511-000	11
3003-7551-0XX*	7	3014-7511-700	16	3029-7211-002	13	3110-7511-500	18
3003-7551-5XX*	14	3017-1511-000	9	3029-7211-003	13	3110-7511-600	18
3003-7551-6XX*	14	3017-1511-500	17	3041-1541-0XX*	6	3110-7511-700	18
3003-7551-7XX*	14	3017-1511-600	17	3041-1551-0XX*	6	3141-1521-0XX*	6
3003-7571-0XX*	7	3017-1511-700	17	3041-7541-0XX*	6	3141-7521-0XX*	6
3003-7571-5XX*	14	3017-7511-000	9	3041-7551-0XX*	6	5252-1501-000	22
3003-7571-6XX*	14	3017-7511-500	17	3042-1511-000	11	5252-1501-500	22
3003-7571-7XX*	14	3017-7511-600	17	3042-1511-006	19	5252-1501-600	22
3004-1511-000	8	3017-7511-700	17	3042-7511-000	11	5252-1501-700	22
3004-1511-500	16	3019-1511-000	8	3042-7511-006	19	5252-7501-000	22
3004-1511-600	16	3019-1511-500	16	3048-1511-000	9	5252-7501-500	22
3004-1511-700	16	3019-1511-600	16	3048-1511-500	17	5252-7501-600	22
3004-7511-000	8	3019-1511-700	16	3048-1511-600	17	5252-7501-700	22
3004-7511-500	16	3019-7511-000	8	3048-1511-700	17	CP-1	26
3004-7511-600	16	3019-7511-500	16	3048-7511-000	9	CP-6	26
3004-7511-700	16	3019-7511-600	16	3048-7511-500	17	TA-0105	26
3005-1541-0XX*	4	3019-7511-700	16	3048-7511-600	17	TA-0436	26
3005-1551-0XX*	4	3025-1511-000	10	3048-7511-700	17		
3005-7541-0XX*	4	3025-1511-005	19	3092-1511-001	13		
3005-7551-0XX*	4	3025-7511-000	10	3092-1511-002	13		
3006-1541-0XX*	7	3025-7511-005	19	3092-1511-003	13		
3006-1541-5XX*	15	3026-1521-0XX	21	3092-7511-001	13		
3006-1541-6XX*	15	3026-1521-2XX	21	3092-7511-002	13		

* Indicates cable connectors with various types on specified page.



APPLIED ENGINEERING PRODUCTS

(203) 776-2813 • FAX (203) 776-8294

www.aepconnectors.com • aepsales@aepconnectors.com

About Applied Engineering Products

Since our foundation in 1973, we have always believed that having our customers take a look "inside AEP" is important in fostering strong vendor/customer relationships. We are proud of our physical plant and equipment, but even more so of our dedicated staff. When customers see first-hand how AEP's people keep a constant focus on maintaining and improving

customer service and satisfaction, the reason for our consistently strong on-time delivery and quality records becomes clear.

We invite you to see for yourself. Call us to arrange a plant tour—or, if you can't make a visit, ask for your copy of *INSIDE AEP*, our facilities and capabilities brochure.



APPLIED ENGINEERING PRODUCTS

(203) 776-2813 • FAX (203) 776-8294

www.aepconnectors.com • aepsales@aepconnectors.com

The SLB connectors in this brochure are only part of our complete line of subminiature coaxial connectors and cable assemblies, including:

- SMA
- SMB
- SMC
- SSMB
- SSMC
- SLB (Slide-on version of SMB)
- SSLB (Slide-on version of SSMB)
- 75Ω Snap-on mating
- 75Ω Screw-on mating
- Adapters within and between series
- Flexible cable assemblies
- Semi-rigid cable assemblies
- And over 100 styles of MIL-PRF-39012 QPL connectors in series SMA, SMB, and SMC

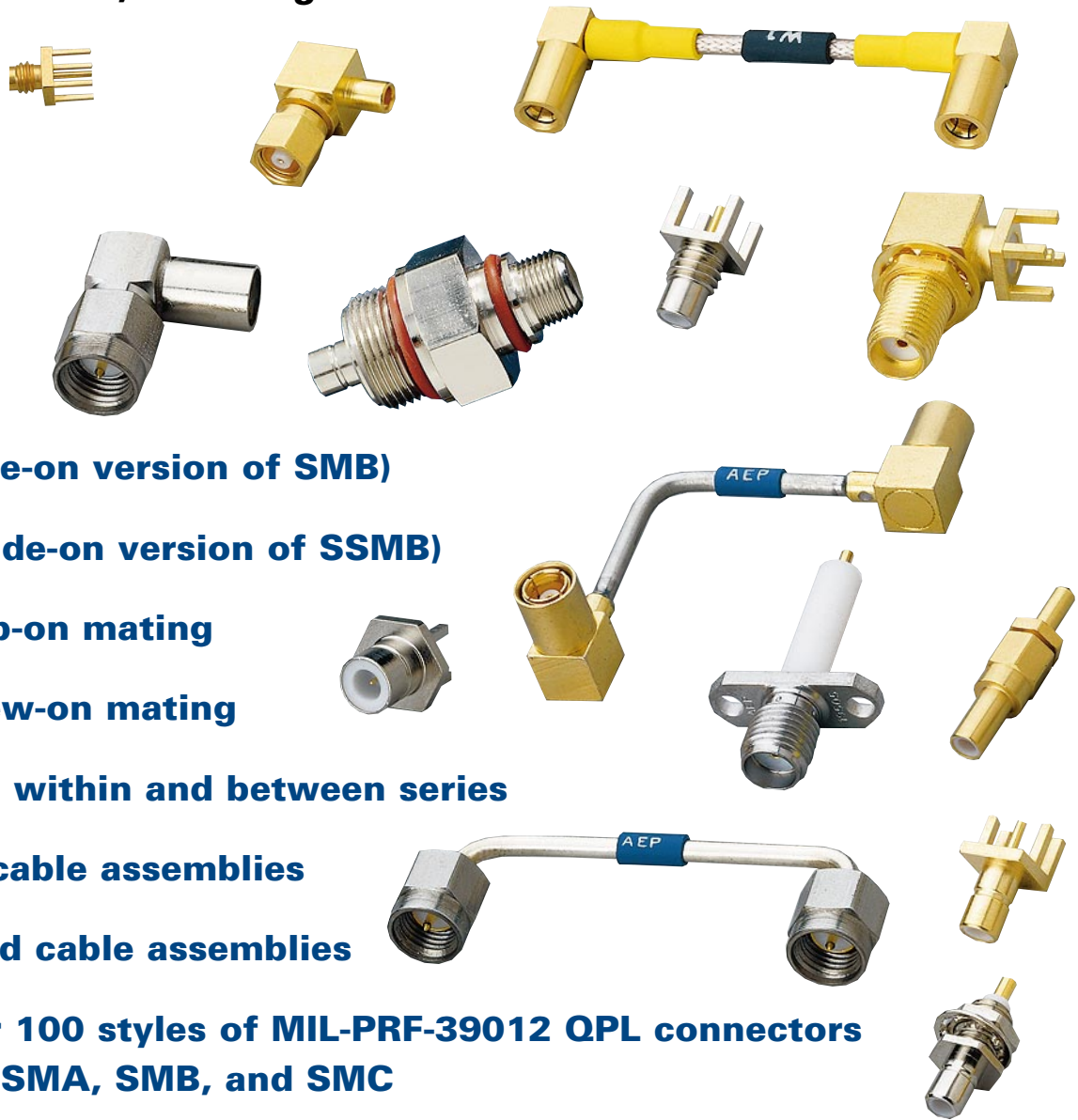

Call for your copy of our 184-page full catalog to see them all.



ISO 9001
CERTIFIED



APPLIED ENGINEERING PRODUCTS

104 John W. Murphy Drive • P.O. Box 510 • New Haven, CT 06513

(203) 776-2813 • FAX (203) 776-8294

www.aepconnectors.com • e-mail: aepsales@aepconnectors.com